

# Crawford QCD Standard Quick Change Collet Chucks

## Straight Recess DIN 6353

- ⓘ Ideal for both bar and secondary operation,
- ⓘ Dead Length Operation
- ⓘ QCD Standard Length Chucks use DIN type Multi-Bore Collets for a powerful parallel grip over a wide diameter range. When gripping short components or where marking of a finished diameter is to be avoided use the B type spring Collet of a fixed bore size Collet.
- ⓘ Collets are available for round, Hex or Square Stock.
- ⓘ Large Capacity- QSD Chuck maximum round 2.36" (60mm)
- ⓘ Save set up time-Quick Change Bayonet Cap Design
- ⓘ Accurate-.0002" TIR from rear mounting register and working collet taper.
- ⓘ Repeatability .0002" on duplicate parts
- ⓘ Straight recess mount form DIN 6353 for A type spindle call for availability
- ⓘ 1 Year Warranty

Uses Din 6343 Multibore Collets see page 124  
or B Type Spring Collets see page 116-120

- (1) Weight shown for chucks are net and do not include either collets or drawbar adapters
- (2) Each collet size requires a polyurethane chip Chuck Seal.
- (3) Additional Quick Change Chuck Caps can be ordered for pre-loading collets and further reducing downtime.
- (4) Backstop cannot be used with Spring Collets

C† Maximum drawtube thread 'C'

D† Maximum drawtube length retracted 'D'

E† Maximum forward stroke required

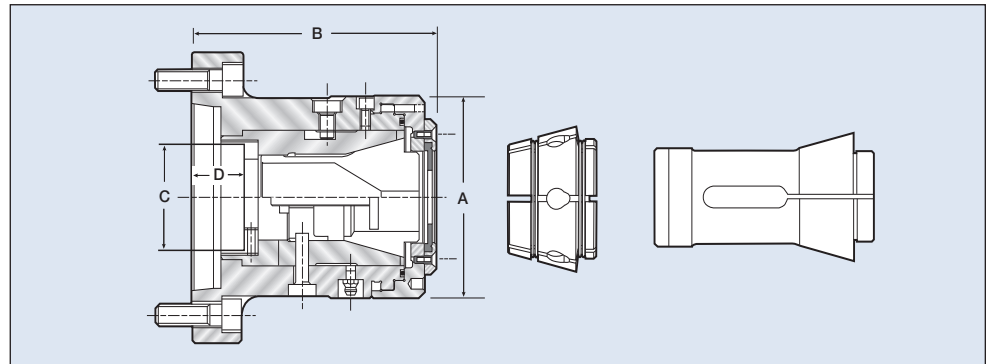

### QCD Series for Multibore or Spring DIN Standard type Collets

Chuck Type	QCD-42	QCD-60
Mount	140 x 60	170 x 6
Multibore Collet	M-673	M-677
Capacity Round (mm/in)	42/1.65	60/2.36
Capacity Hex (mm/in)	36/1.41	52/2.04
Capacity Square (mm/in)	29/1.14	42/1.65
(4)Spring Collet	4728 (B42)	4291 (B60)
A (mm/in)	114/4.49	146/5.75
B (mm/in)	147/5.79	191/7.52
C† (mm/in)	60/2.36	70/2.76
D† (mm/in)	31/1.22	48/1.89
E† (mm/in)	9/.35	10/.39
(1) Chuck Weight	19 lbs	30.9 lbs
Drawbar Force (lb/f)	5,392	5,392
Clamping Force (lb/f)	13,199	13,199
Maximum RPM	6000	6000
(2)Chuck Seal Part No.	D-237	D-485
(3)Chuck Cap Part No.	C-428GA	C-142GA
Ejector Part No.	D-242	D-490
Backstop Part No.	D-241	D-489
Chuck Order No.	D-634	D-636

HOW TO ORDER: State quantity, Model Number of chuck and shipping instructions.