



Atlas Workholding 2 Jaw Long Stroke Power Chuck

PTH 5" - 12" Chucks

- ⊕ 2 jaw closed center long stroke power chuck
- ⊕ Draw bar activated
- ⊕ Use where jaws need to overcome part obstructions like valve bodies and flanges
- ⊕ Adapter mounted
- ⊕ 1.5mm serration pitch on 5" - 10" chucks, 3mm on 12" chucks

Model No.	Jaw Stroke Dia	Sleeve Stroke	Gripping Capacity		Draw Bar Pull lb/f	Grip Force lb/f	Max RPM	Wt lbs
			Max	Min				
PTH6-A4	.512"	.709"	6.5"	.787"	2,204	4,850	3500	22
PTH6-A5	.512"	.709"	6.5"	.787"	2,204	4,850	3500	22
PTH6-A6	.512"	.709"	6.5"	.787"	2,204	4,850	3500	22
PTH8-A6	.630"	.866"	8.26"	.866"	4,408	9,700	3000	44
PTH8-A8	.630"	.866"	8.26"	.866"	4,408	9,700	3000	44
PTH10-A6	.709"	.984"	9.84"	.984"	5,070	11,023	2500	71
PTH10-A8	.709"	.984"	9.84"	.984"	5,070	11,023	2500	71
PTH12-A8	.787"	1.102"	11.81"	1.102"	6,613	14,550	2000	119
PTH12-A11	.787"	1.102"	11.81"	1.102"	6,613	14,550	2000	119

Power Chucks

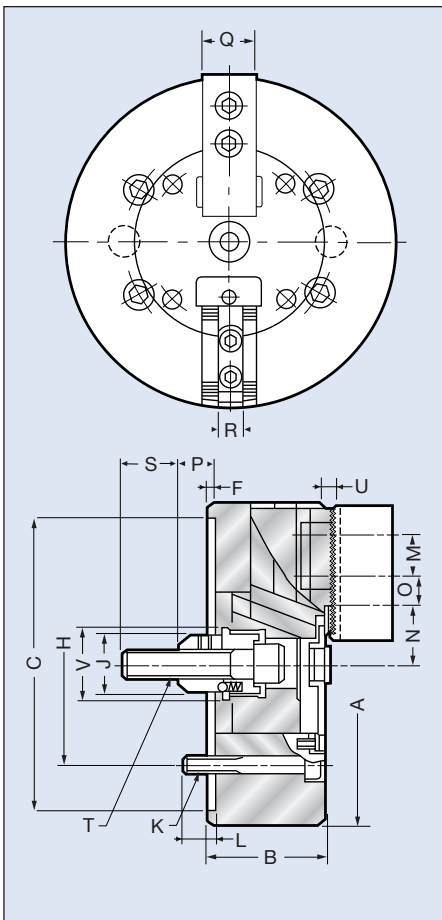

Dimensional Data (in inch)

MODEL	PTH-6	PTH-8	PTH-10	PTH-12
A	6.50	8.26	10	11.97
B	2.480	3.031	3.346	3.819
C	5.512	7.480	9.055	11.024
F	.197	.197	.197	.197
H	4.125	5.250	5.250	6.750
J	1.260	1.496	1.969	2.047
K	4-M10	4-M12	6-M16	6-M16
L	.669	.828	.906	.984
M	.787	.984	1.181	1.575
N max.	1.528	1.685	1.921	2.264
N min	1.272	1.370	1.567	1.870
O max.	.709	1.181	1.594	1.772
O min	.295	.531	.591	.591
P max.	1.142	1.339	1.732	1.969
P min	.433	.472	.748	.866
Q	1.181	1.378	1.575	1.969
R	.472	.630	.709	.827
S	1.417	1.417	1.811	1.969
T	M16x2.0	M20x2.5	M24x3.0	M24x3.0
U	.197	.197	.197	.197
V	---1.496	1.88	2.283	2.559

HOW TO ORDER: State quantity, Model Number of chuck and shipping instructions.