



Atlas Workholding 2 Jaw High Speed Open Center Power Chuck

HST 6" - 12" Chucks

- ⊕ 1.5mm x 60° master jaw
- ⊕ Repeatability ± .0005"
- ⊕ Large thru-hole
- ⊕ Hardened jaw ways and all internal parts
- ⊕ All steel body
- ⊕ High RPM

Power Chucks

Model No.	Mount	Thru Hole Dia	Jaw Stroke Dia	Sleeve Stroke	Gripping Capacity		Draw Bar Pull lb/f	Grip Force lb/f	Max RPM	Wt lbs	
					Max	Min					
HST6-A5	(D)	A2-5	1.771"	.216	.472	6.65	.590	4,945	12,813	6000	30
HST8-A5	(I)	A2-5	2.047"	.291"	.630"	8.27"	.512"	7,824	19,332	5000	52
HST8-A6	(D)	A2-6	2.047"	.291"	.630"	8.27"	.512"	7,824	19,332	5000	52
HST10-A6	(I)	A2-6	2.952"	.346"	.748"	10.00"	1.220"	9,667	24,953	4200	91
HST10-A8	(D)	A2-8	2.952"	.346"	.748"	10.00"	1.220"	9,667	24,953	4200	91
HST12-A6	(I)	A2-6	3.582"	.417"	.905"	11.97"	1.653"	12,363	32,372	3300	148
HST12-A8	(D)	A2-8	3.582"	.417"	.905"	11.97"	1.978"	12,363	32,372	3300	141
HST12-A11	(I)	A2-11	3.582"	.417"	.905"	11.97"	1.978"	12,363	32,372	3300	141

(I) Indirect mount (D) Direct mount

Dimensional Data (in inch)

MODEL	HST6-A5	HST8-A5	HST8-A6	HST10-A6	HST10-A8	HST12-A6	HST12-A8	HST12-A11
A	6.63	8.26	8.26	10.00	10.00	11.97	11.97	11.97
B	3.582		4.055	4.724	4.449	5.079	4.832	
C	5.512	6.693	6.693	8.661	8.661	8.661	8.661	8.661
D	3.201	3.201	4.188	4.188	5.501	4.188	5.501	7.751
E	.590		.669	.984	.708	.984	.708	
F	.167	.167	.167	.167	.167	.236	.236	.236
G	4.126	5.252	5.252	6.748	6.748	6.748	6.748	6.748
H	4.126		5.252	5.252	6.748	5.252	6.748	9.250
J	1.771	2.047	2.047	2.953	2.953	3.582	3.582	3.582
K	6-M10	6-M12	6-M12	6-M16	6-M16	6-M16	6-M16	6-M16
L	.630		.708	.728	.945	.728	.984	
M	.787	.984	.984	1.181	1.181	1.181	1.181	1.181
N max	1.259	1.523	1.523	2.007	2.007	2.413	2.413	2.413
N min	1.151	1.378	1.378	1.834	1.834	2.204	2.204	2.204
O max	.895	1.171	1.171	1.329	1.326	1.801	1.801	1.801
O min	.364	.581	.581	.581	.581	.620	.620	.620
P max	1.023		1.240	1.319	1.043	1.299	1.299	1.299
P min	.551		.610	.571	.295	.394	.394	.394
Q	1.220	1.378	1.378	1.575	1.575	1.968	1.968	1.968
R	.472	.551	.551	.630	.630	.827	.827	.827
S	.748	.807	.807	.984	.984	1.102	1.102	1.102
T	.0789	.0789	.0789	.0789	.0789	.0789	.0789	.0789
U max	M55x2.0	M60x2.0	M60x2.0	M85x2.0	M85x2.0	M90x2.0	M100x2.0	
V	-	6-M10	-	6-M12	-	6-M12	-	6-M20
W	2.362	2.598	2.598	3.701	3.701	4.252	4.252	4.252
X	.787	1.181	1.181	1.771	1.771	1.968	1.968	1.968
Y	1.142	1.535	1.535	1.693	1.693	2.009	2.009	2.009
Z	2.834	3.740	3.740	4.331	4.331	4.370	4.370	4.370

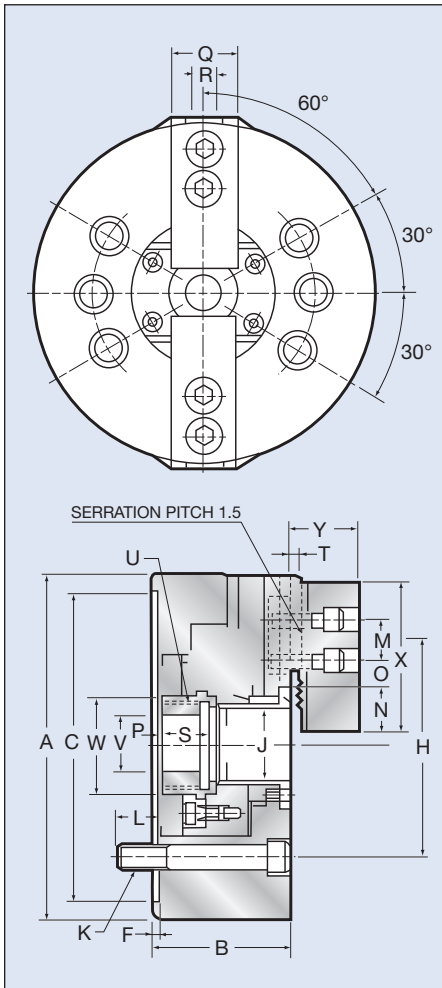

HOW TO ORDER: State quantity, Model Number of chuck and shipping instructions.