



Collet Type Rotary Power Chuck



Jaw Pad Type Rotary Power Chuck

Uses Jaw Pads see page 128



Atlas Workholding Air/Hydraulic Rotary Power Chuck

- ⊕ Air/Hydraulic cylinder is built-in. no need for extra cylinders
- ⊕ 0.030mm-0.050mm/.001"-.002" repeatability for collet type chucks
- ⊕ 0.050mm-0.080mm/.002"-.003" repeatability for jaw pad type power chuck
- ⊕ Aluminum alloy chuck body, light-weight, good heat dispensation
- ⊕ Allows non-stop operation when loading parts
- ⊕ Widely applied to convert manual lathes into powered lathes
- ⊕ Widely applied to build special purpose machines
- ⊕ Do not spray cutting fluid to the chuck directly
- ⊕ JA7-44/JH7-44: I.D. chucking possible by installing a mandrel and a pushing nut
- ⊕ New Function: JH7-70/JH9-90/JH9-120 can be actuated by pneumatic by installing an optional air booster
- ⊕ 1-set of Jaw Pads come with Jaw Pad type Rotary Power Chuck
- ⊕ 1 Year Warranty

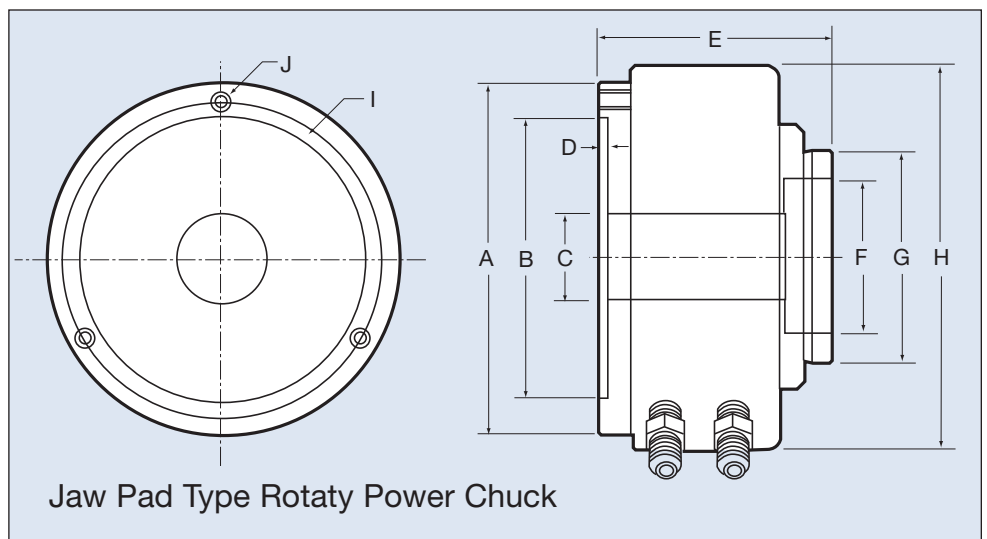
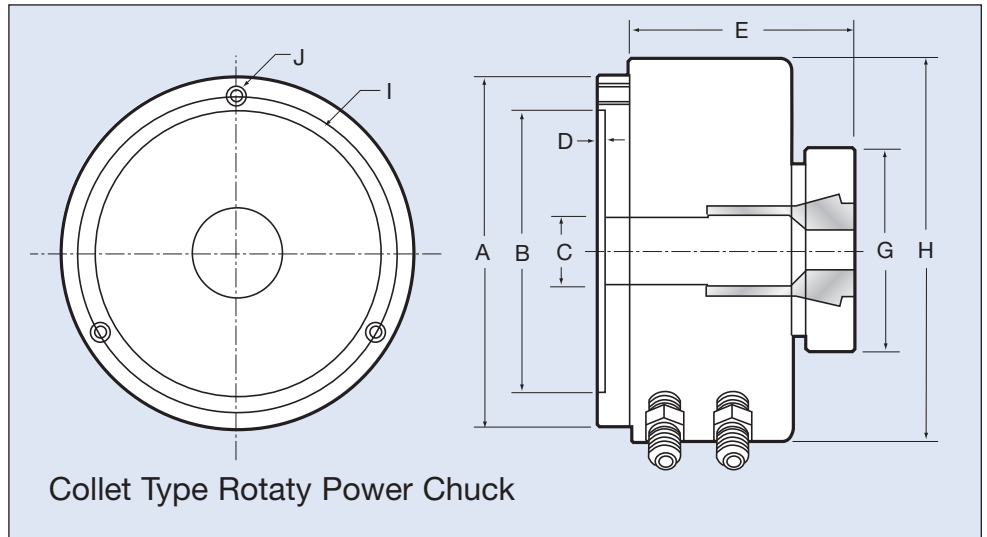



Atlas Workholding Air/Hydraulic Rotary Power Chuck Dimensions/Specifications

Collet Type Rotary Power Chuck

Order Number	JA7-44/JH7-44
A (mm/in)	192/7.56
B (mm/in)	155/6.10
C (mm/in)	44/1.37
D (mm/in)	5/0.20
E (mm/in)	135/5.31
F (mm/in)	-
G (mm/in)	110/4.33
H (mm/in)	212/8.35
I (mm/in)	172/6.77
J (mm/in)	M10 x P1.5-3
Working Collet/Jaw Pads	C-44 Collet Expanding Kit
Air/Hydro Actuated	Air/Hydro
Operating Pressure	2-20kg/cm ² 28-286psi
Max. rpm	1600
Max. Capacity Through/ Non-Through	44mm/1.73"
Piston Area	116cm ² /18in ²
Max. Clamping Force	9150kgf@16kg/cm ² 20130lbf@229psi
Net Weight	17kgs/37.4lbs

Jaw Pad Type Rotary Power Chuck - Air Actuated

JA5-25	JA7-40	JA7-70
135-5.31	192/7.56	192/7.56
100/3.94	155/6.10	155/6.10
27/1.06	47/1.85	68/2.68
4/0.16	5/0.20	5/0.20
105/4.13	128/5.04	142/5.60
45/1.77	65/2.56	105/4.13
68/2.68	94/3.70	168/6.61
170/6.69	212/8.35	266/10.47
115/4.53	172/6.77	172/6.77
M8 x P1.25-3	M10 x P1.5-3	M10 x P1.5-3
C-25 Jaw Pad	C-40 Jaw Pad	C-70 Jaw Pad
Air	Air	Air
2-9kg/cm ² 28-130psi	2-9kg/cm ² 28-130psi	2-9kg/cm ² 28-130psi
1800	1600	1400
25mm/32mm 0.98"/1.26"	45mm/50mm 1.77"/1.97"	68mm/90mm 2.68"/3.54"
115cm ² /17.8in ²	182cm ² /28.2in ²	328cm ² /50.8in ²
2680kgf@7kg/cm ² 2896lbf@100psi	4250kgf@7kg/cm ² 9350lbf@100psi	7700kgf@7kg/cm ² 16940lbf@100psi
7.5kgs/16.5lbs	15.0kgs/33lbs	22.5kgs/49.5lbs

Jaw Pad Type Rotary Power Chuck - Hydraulic Actuated

Order Number	JH5-25	JH7-40	JH7-70	JH9-90	JH9-120
A (mm/in)	135/5.31	192/7.56	192/7.56	230/9.06	230/9.06
B (mm/in)	100/3.94	155/6.10	155/6.10	190/7.48	190/7.48
C (mm/in)	26/1.02	45/1.77	68/2.68	88/3.52	120/4.72
D (mm/in)	4/0.16	5/0.20	5/0.20	6/0.24	6/0.24
E (mm/in)	105/4.13	128/5.04	142/5.60	150/5.91	160/6.30
F (mm/in)	45/1.77	65/2.56	105/4.13	105/4.13	140/5.51
G (mm/in)	68/2.68	94/3.70	136/5.35	136/5.35	168/6.61
H (mm/in)	138/5.43	192/7.56	211/8.31	232/9.13	275/10.33
I (mm/in)	115/4.53	172/6.77	172/6.77	210/8.27	210/8.27
J (mm/in)	M8 x P1.25 x 3	M10 x P1.5 x 3	M10 x P1.5 x 3	M12x P1.75 x 3	M12x P1.75 x 3
Working Jaw Pads	C-25 Jaw Pad	C-40 Jaw Pad	C-70 Jaw Pad	C-70 Jaw Pad	C-120 Jaw Pad
Air/Hydro Actuated	Hydraulic	Hydraulic	Hydraulic or Pressure Boosted Air	Hydraulic or Pressure Boosted Air	Hydraulic or Pressure Boosted Air
Operating Pressure	10-25kg/cm ² 143-357psi	10-20kg/cm ² 143-286psi	10-20kg/cm ² 143-286psi	10-15kg/cm ² 143-214psi	10-15kg/cm ² 143-214psi
Max rpm	1800	1600	1400	1100	900
Max. Capacity Through/ Non-Through	25mm/32mm 0.98"/1.26"	45mm/50mm 1.77"/1.97"	68mm/90mm 2.68"/3.54"	88mm/88mm 3.52"/3.52"	118mm/118mm 4.65"/4.65"
Piston Area	56cm ² /8.68in ²	90cm ² /13.9in ²	116cm ² /18in ²	132 ² /20.5in ²	183cm ² /28.4in ²
Clamping Force	3330kgf@16kg/cm ² 7326lbf@228psi	5350kgf@16kg/cm ² 11770lbf@228psi	6920kgf@16kg/cm ² 15524lbf@228psi	7870kgf@16kg/cm ² 17314lbf@228psi	8150kgf@12kg/cm ² 17930lbf@171psi
Net Weight	6kgs/13.2lbs	13kgs/28.6lbs	18kgs/39.6lbs	24kgs/52.8lbs	30kgs/66lbs