



Atlas Workholding JASR Stationary Dead Length Collet Chuck

Use for Pallets, Tombstones, Machining Centers, Standard Mills and Drill Presses

Uses 5C Collets see page 112-113
 or 16C Collets see page 114-115
 or B42 Collets see page 116-117
 or B60 Collets see page 118-119
 or B80 Collets see page 120

- ⊕ Powered by Air
- ⊕ Small Foot Print
- ⊕ Low Cost
- ⊕ Easily to Install
- ⊕ 5C, 16C, B42, B60 and B80 models available
- ⊕ Repeatability Plus Minus .0006"-.0012" (0.015-0.025mm)
- ⊕ Dead Length Design
- ⊕ For Best Accuracy Use High Quality Crawford Collets
- ⊕ Lever or Foot Pedal Actuated
- ⊕ Low Maintenance with Oil Mist Lubrication System
- ⊕ High Resistance to Coolant and Chip Penetration
- ⊕ Low Maintenance, Long Life

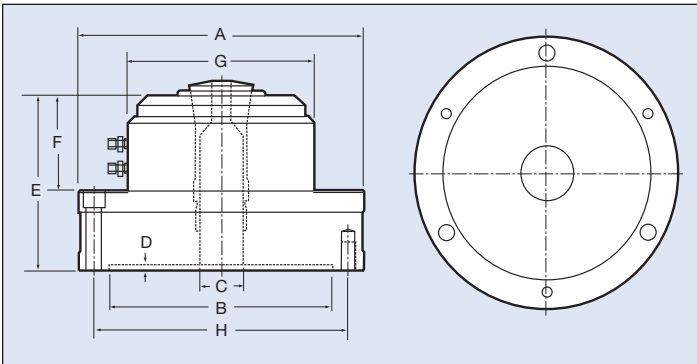

JASR-5C/JASR-16C Collet Type

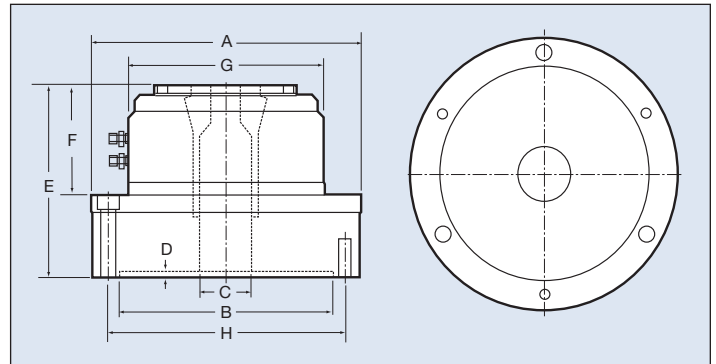

JASR-B42/JASR-B60/JASR-B80 Collet Type

Order Number	JASR-5C	JASR-16C	JASR-B42	JASR-B60	JASR-B80
A (mm/in)	168/6.61	197/7.76	196/7.72	207/8.15	246/9.67
B (mm/in)	130/5.12	160/6.30	155/6.10	170/6.69	200/7.87
C (mm/in)	26/1.02	40/1.57	42/1.65	60/2.36	80/3.15
D (mm/in)	5/0.20	5/0.20	5/0.20	5/0.20	5/0.20
E (mm/in)	100/3.94	112/4.41	138/5.43	148/5.83	152/5.98
F (mm/in)	55/2.17	64/2.52	77/3.03	86/3.39	80/3.15
G (mm/in)	110/4.33	130/5.12	144/5.67	168/6.61	196/7.72
H (mm/in)	147/5.79	176/6.93	172/6.77	186/7.32	226/8.90
Mounting Screw Hole	φ9.0x4	φ11.0x3+M10xP1.5x3	φ11.0x3+M10xP1.5x3	φ11.0x3+M10xP1.5x3	φ11.0x6 for M10
Air/Hydro Actuated	Air	Air	Air	Air	Air
Working Collet	5C Collet	16C Collet	B42 Collet	B60 Collet	B80 Collet
Operating Pressure	3-8kg/cm ² 43-114psi	3-8kg/cm ² 43-114psi	3-8kg/cm ² 43-114psi	3-8kg/cm ² 43-114psi	3-8kg/cm ² 43-114psi
Chuck Thru-Hole	26mm/1.02"	40mm/1.57"	42mm/1.65"	60mm/2.36"	80mm/3.15"
Clamping Force	4825 kgf@7kg/cm ² 10615 lbf@100psi	5600 kgf@7kg/cm ² 12320 lbf@100psi	5960 kgf@7kg/cm ² 13112 lbf@100psi	7250 kgf@7kg/cm ² 15950 lbf@100psi	9060 kgf@7kg/cm ² 19932 lbf@100psi
Net Weight	10 kgs/22 lbs	14 kgs/31 lbs	17 kgs/37 lbs	32 kgs/71 lbs	32 kgs/71 lbs

HOW TO ORDER: State quantity, Model Number of chuck and shipping instructions.

Collet Chucks