



Atlas Workholding Stationary ATL225-5C JAS/JHS Dead Length Collet Chuck

**Use for Pallets, Tombstones, Machining Centers,
Standard Mills and Drill Presses**

Uses 5C Collets see page 112-113
or Jaw Pads see page 128

- ⊕ Powered by Air and/or Hydraulics
- ⊕ Small Foot Print
- ⊕ Low Cost
- ⊕ Easily to Install
- ⊕ Repeatability Plus Minus .0012"-.002" (0.030-0.050mm)
- ⊕ Dead Length Design
- ⊕ Lever or Foot Pedal Actuated
- ⊕ Low Maintenance with Oil Mist Lubrication System
- ⊕ High Resistance to Coolant and Chip Penetration
- ⊕ Low Maintenance, Long Life
- ⊕ JAS-40, JHS-40 & JHS-70 come with 1-set of jaw pads

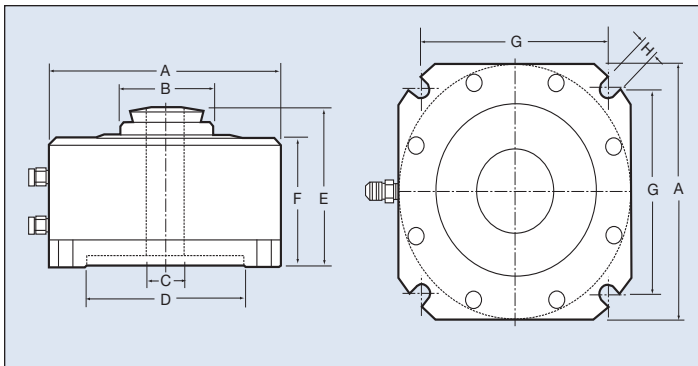

ATL225-5C Collet Type

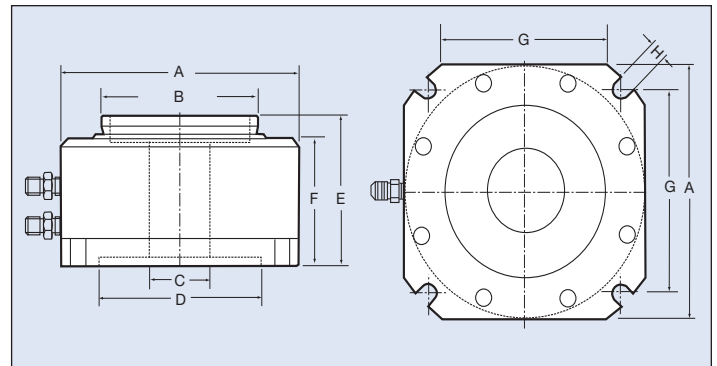

JAS-40/JHS-40/JHS-70 Jaw Pad Type

Order Number	ATL225-5C	JAS-40	JHS-40	JHS-70
A (mm/in)	144/5.67	168/6.61	144/5.67	188/7.40
B (mm/in)	55/2.17	95/3.74	95/3.74	136/5.35
C (mm/in)	26/1.02	38/1.50	38/1.50	68/2.68
D (mm/in)	100/3.94	100/3.94	100/3.94	155/6.10
E (mm/in)	95/3.74	96/3.78	94/3.70	96/3.78
F (mm/in)	75/2.95	76/2.99	73/2.87	73/2.87
G (mm/in)	117/4.65	136/5.35	118/4.65	155/6.10
H (mm/in)	8.5/0.33	11/0.43	8.5/0.33	11/0.43
Working Collet/Jaws	5C Collet	C-40 Pads	C-40 Pads	C-70 Pads
Air/Hydro Actuated	Air	Air	Hydraulic	Hydraulic
Operating Pressure	3-15kg/cm ² 43-214psi	3-8kg/cm ² 43-114psi	3-20kg/cm ² 43-286psi	3-20kg/cm ² 43-286psi
Capacity Min. Max.	1.0mm/1/16" 27mm/1-1/8"	5mm/.1968" 38mm/1.5"	5mm/.1968" 38mm/1.5"	5mm/.1968" 68mm/2.677"
Piston Area	112cm ² /17.4in ²	216cm ² /33.5in ²	82cm ² /12.7in ²	106cm ² /16.4in ²
Clamping Force	4950 kgf@7kg/cm ² 10890 lbf@100psi	5550 kgf@7kg/cm ² 12210 lbf@100psi	6100 kgf@20kg/cm ² 13420 lbf@286psi	7800 kgf@20kg/cm ² 17160 lbf@286psi
Net Weight	9 kgs/19.8 lbs	12.5 kgs/27.5 lbs	8.5 kgs/18.7 lbs	13.5 kgs/29.7 lbs

HOW TO ORDER: State quantity, Model Number of chuck and shipping instructions.