



Atlas Air Powered Front Mount 5C Dead Length Collet Chucks

**No Draw-tube or Air Feed Tubes Required: for Lathes,
Rotary Tables and Grinders: Series ATL206-5C**

**Collet Chuck Order No.
with Mount:**

ATL206-5C

Straight Recess Mount

Type A Mount

ATL206-5CA4

ATL206-5CA5

ATL206-5CA6

ATL206-5CA8

Type D Mount

ATL206-5CD3

ATL206-5CD4

ATL206-5CD5

ATL206-5CD6

ATL206-5CD8

Other Mounts

ATL206-5C43-2¼-8

ATL206-5C44-4°-Taper

ATL206-5C45-2¾-10

ATL206-5C46-2¾-6

**Collet Chuck
Supplied with:**

- 2 Filter Bars
- 2 Air Hoses
- 1 Fixing Bracket for Hoses
- 1 5C Collet Wrench
- 1 Hex Key
- Mounting Bolts
- Users Manual

- ⊕ No Hydraulic System Required
- ⊕ No Draw Tube or Air Feed Tubes Restricting Spindle Bore
- ⊕ No Rear Cylinders and Cylinder Adapters
- ⊕ Low Cost
- ⊕ Easily Convert any Lathe or Grinder into a Production Machine
- ⊕ Ideal for Rotary Table Applications
- ⊕ Change from Collet Chuck to Standard Chuck Quick and Easy
- ⊕ High Speed 5000 RPM
- ⊕ High Accuracy Less Than .001" TIR
- ⊕ Repeats on Duplicate Parts Plus Minus .00015"
- ⊕ Dead Length Design
- ⊕ For Best Accuracy Use High Quality Crawford Collets
- ⊕ Lever or Foot Pedal Actuated
- ⊕ Low Maintenance with Oil Mist Lubrication System
- ⊕ High Resistance to Coolant and Chip Penetration
- ⊕ Uses 5C Collets, Range 1/64" (.5mm) to 1-1/8" (27mm)
- ⊕ Available in A, D, L, 4 Degree, Threaded and Straight Recess Mounting

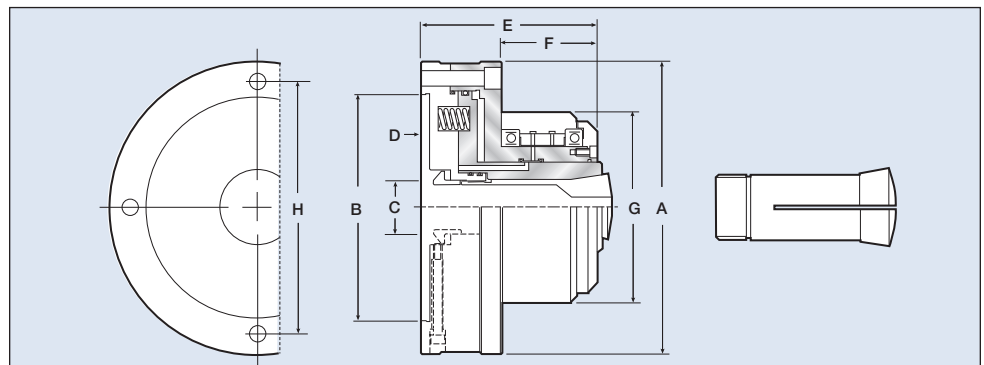

Collet Chuck	ATL206-5C
A	168mm (6.61")
B	130mm (5.12")
C	26mm (1.02")
D	5mm (0.20")
E	100mm (3.94")
F	55mm (2.17")
G	106mm (4.17")
H	147mm (5.79")

Specifications	ATL206-5C
Screw Hole Dia	9mm (0.35") x 4
Collet Type	5C Collets
Max. RPM	5000
Sleeve Stroke	4mm (0.16")
Air Pressure	3-8 kg/cm ² (42-114 psi)
Through Hole Dia	26mm (1.06")
Chuck Weight	10kg (22lbs)
Grip Force	10,500 lbs @ 100 PSI

NOTE: "E" shown is for model ATL206-5C Collet Chuck with no mounting plate. Add 3/4" to the "E" dimension for mounting plate. This will vary slightly depending on the mounting required. If an exact "E" dimension is required, consult factory.

OPTIONS: Order No: **LEV100** Lever Control Package: (Includes: Lever Control, Line Filter, Lubricator and regulator.

Order No: **FOT200** Foot Pedal Control Package: (Includes: Foot Pedal, Line Filter, Lubricator and regulator.