

# Crawford QCD Standard Quick Change Collet Chucks

## For A Type Spindles

- ⓘ Ideal for both bar and secondary operation,
- ⓘ Dead Length Operation
- ⓘ QCD Standard Length Chucks use DIN type Multi-Bore Collets for a powerful parallel grip over a wide diameter range. When gripping short components or where marking of a finished diameter is to be avoided use the B type spring Collet of a fixed bore size Collet.
- ⓘ Collets are available for round, Hex or Square Stock.
- ⓘ Large Capacity- QCD Chuck maximum round 2.36" (60mm)
- ⓘ Save set up time-Quick Change Bayonet Cap Design
- ⓘ Accurate-.0002" TIR from rear mounting register and working collet taper.
- ⓘ Repeatability .0002" on duplicate parts
- ⓘ Design for A type spindles and Din 55026. For other spindle mounts call for availability
- ⓘ 1 Year Warranty

- (1) Weight shown for chucks are net and do not include either collets or drawbar adapters
- (2) Each collet size requires a polyurethane chip Chuck Seal.
- (3) Additional Quick Change Chuck Caps can be ordered for pre-loading collets and further reducing downtime.
- (4) Backstop cannot be used with Spring Collets
- C† Maximum drawtube thread 'C'
- D† Maximum drawtube length retracted 'D'
- E† Maximum forward stroke required

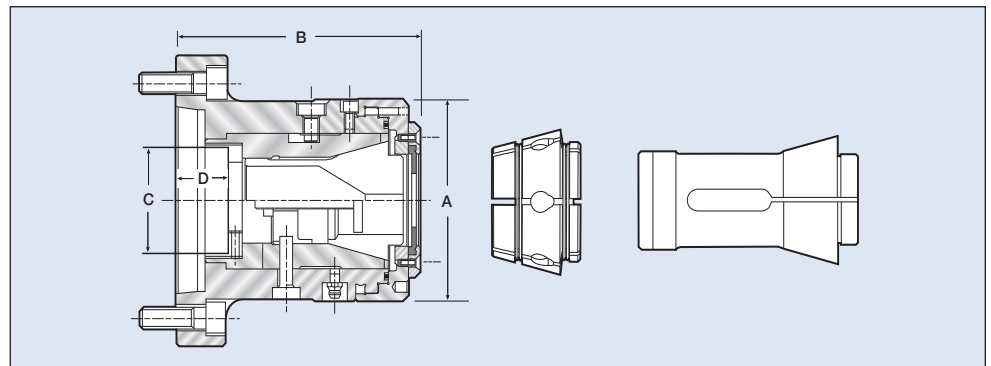

### QCD Series for Multibore or Spring DIN Standard type Collets

Chuck Type	QCD-42	QCD-42	QCD-60	QCD-60
Mount	A2-5	A2-6	A2-6	A2-8
Multibore Collet	M-673	M-673	M-677	M-677
(4)Spring Collet	B42-4728	B42-4728	B60-4291	B60-4291
Capacity Round (mm/in)	42/1.65	42/1.65	60/2.36	60/2.36
Capacity Hex (mm/in)	38/1.50	38/1.50	52/2.05	52/2.05
Capacity Square (mm/in)	30/1.18	30/1.18	42/1.65	42/1.65
A (mm/in)	114/4.49	114/4.49	146/5.75	146/5.75
B (mm/in)	147/5.79	147/5.79	191/7.52	191/7.52
C† (mm/in)	60/2.36	60/2.36	70/2.76	70/2.76
D† (mm/in)	31/1.22	31/1.22	48/1.89	48/1.89
E† (mm/in)	9/.35	9/.35	10/.39	10/.39
(1) Chuck Weight	19 lbs	19.8 lbs	28.1 lbs	30.9 lbs
Drawbar Force (lb/f)	5,392	5,392	8,536	8,536
Clamping Force (lb/f)	13,199	13,199	22,200	22,200
Maximum RPM	6000	6000	6000	4500
(2)Chuck Seal Part No.	D-237	D-237	D-485	D-485
(3)Chuck Cap Part No.	C-428GA	C-428GA	C-142GA	C-142GA
Ejector Part No.	D-242	D-242	D-490	D-490
Backstop Part No.	D-241	D-241	D-678	D-678
Chuck Order No.	D-233	D-234	D-475	D-477