

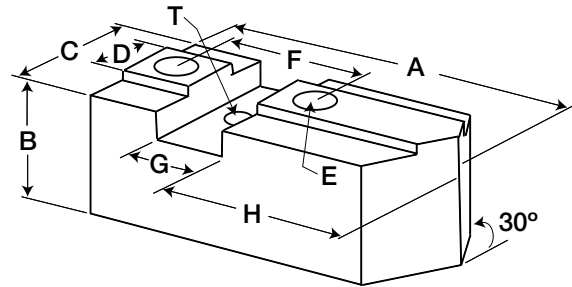

Atlas Workholding Top Tooling American Standard Acme Serrations

For: Pratt Burnerd, Buck, Cushman, S. P. and others

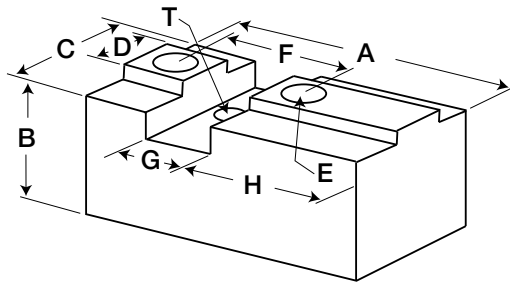

Soft Jaws

Chuck Size	Part Number	Length A	Height B	Width C	Tongue D	Bolt Size E	Hole Spacing F	Key Slot G	H	Tapped Hole T	Offset Pointed Part Number	Offset Pointed A	H	Extra High Part Number	Extra High B
8"	7749-22038	3.75"	2.0"	1.5"	.67"	1/2"	1.25	.601"	2.12"	10-24	7749-22038OP	N/A		7749-22038EH	N/A
10"	7749-26047	4.12"	2.31"	1.75"	.75"	1/2"	1.75"	1.031"	2.12"	5/16"-18	7749-26047OP	5.5"	3.5"	7749-26047EH	3.31"
12"	7749-32056	5.12"	2.31"	1.75"	.875"	5/8"	2.0"	1.031"	2.87"	5/16"-18	7749-32056OP	5.5"	3.25"	7749-32056EH	3.31"
15",18"&20"	8140-40533	6.0"	3.31"	2.5"	1.0"	3/4"	2.5"	1.531"	2.62"	3/8"-16	8140-40533OP	7.5"	4.25"	8140-40533EH	4.81"
21"-UP	8140-50533	6.0"	3.31"	3.0"	1.25"	7/8"	3.0"	1.531"	2.62"	3/8"-16	8140-50533OP	7.5"	4.25"	8140-50533EH	4.81"

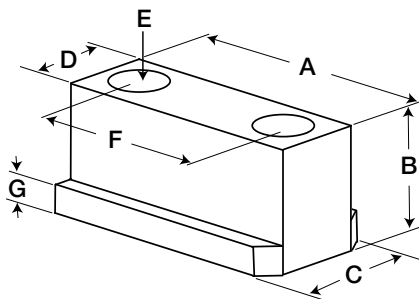

T-Nuts

Chuck Size	Part Number	Length A	Height B	Width C	Neck D	Bolt Size E	Hole Spacing F	Shoulder G
8"	2749-02407	2.0"	1.0"	.94"	.670"	1/2"-13	1.25"	.44"
10"	2749-02417	2.5"	.64"	.94"	.678"	1/2"-13	1.75"	.38"
12"	2749-02427	3.0"	.74"	1.06"	.802"	5/8"-11	2.0"	.44"
15",18"&20"	8130-40531	3.5"	.93"	1.25"	.933"	3/4"-10	2.5"	.55"
21&Up	8130-50531	4.25"	1.18"	1.55"	1.159"	7/8"-9	3.0"	.68"

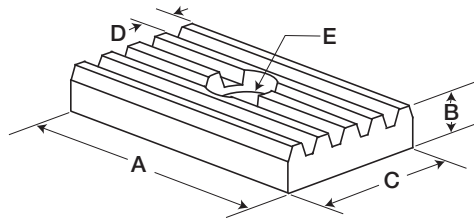

Keys

Chuck Size	Part Number	Length A	Height B	Width C	D	Bolt Size E
8"	2749-02405	1.5"	.38"	.6"	.156"	10-24
10"	2749-02415	1.68"	.5"	1.030"	.25"	5/16"-18
12"	2749-02425	2.13"	.5"	1.030"	.25"	3/8"-16
15" & Up	8130-40530	2.87"	.5"	1.530"	.25"	3/8"-16

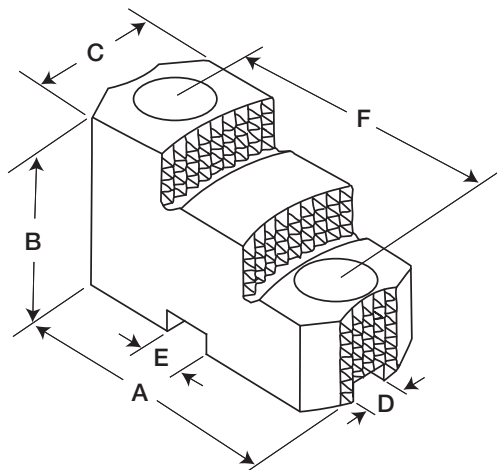

Hard Top Jaws

Chuck Size	Part Number	Length A	Height B	Width C	Tongue D	Slot E	Bolt Spacing F
8"	7749-22036	3.50"	2.0"	1.75"	.67"	.601"	1.25"
10"	7749-26042	4.25"	2.50"	1.75"	.75"	1.031"	1.75"
12"	7749-32052	4.87"	2.50"	1.75"	.87"	1.031"	2.0"
15",18"&20"	8130-40632	5.5"	3.31"	2.5"	1.0"	1.531"	2.5"
21 & UP	8130-50532	6.5"	3.31"	2.5"	1.25"	1.531"	3.0"

Top Tooling