



# Atlas Workholding 'King Bore' Power Chuck

## ATLB Series 6", 8", 10" & 12"

- ⚙ Super large thru-hole
- ⚙ Easy Retrofit
- ⚙ Interchangeable Top Tooling 1.5mm x 60° serrations
- ⚙ High speed
- ⚙ Full 1 year warranty parts and labor
- ⚙ Hardened jaw ways, master jaws and internal parts
- ⚙ Quick Change cover plate for closed center applications.
- ⚙ Chuck accuracy plus/minus .0005" repeatability

Model No.	Mount	Thru Hole Dia	Jaw Stroke Dia	Sleeve Stroke	Gripping Capacity		Draw Bar Pull lb/f	Grip Force lb/f	Max RPM	Wt lbs
					Max	Min				
ATLB6-A5	A2-5	2.047"	.252"	.591"	6.89"	.649"	5,624	12,815	6000	26
ATLB8-A5	A2-5	2.598"	.291"	.689"	8.27"	.905"	7,928	19,554	5000	51
ATLB8-A6	A2-6	2.598"	.291"	.689"	8.27"	.905"	7,928	19,554	5000	51
ATLB10-A6	A2-6	3.030"	.346"	.748"	10.00"	1.220"	24,953	19,554	4200	89
ATLB10-A8	A2-8	3.030"	.346"	.748"	10.00"	1.220"	24,953	19,554	4200	89
ATLB12-A8	A2-8	4.055"	.417"	.905"	12.40"	2.126"	12,363	32,376	2800	123
ATLB12-A11	A2-11	4.055"	.417"	.905"	12.40"	2.126"	12,363	32,376	2800	123

Power Chucks

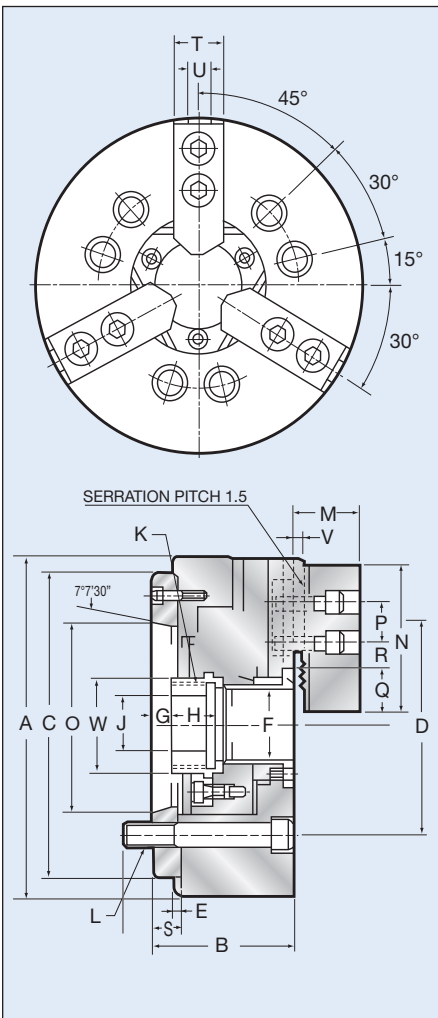

### Dimensional Data (in inch)

MODEL	ATLB6-A5	ATLB8-A5	ATLB8-A6	ATLB10-A6	ATLB10-A8	ATLB12-A8	ATLB12-A11
A	6.889	8.267	8.267	10.00	10.00	12.401	12.401
B	4.173	5.354	5.118	4.724	4.449	5.512	5.827
C	5.512	6.693	6.693	8.661	8.661	11.811	11.811
D	4.126	5.252	5.252	6.748	6.748	9.252	9.252
E	.197	.197	.197	.167	.167	.236	.236
F	2.204	2.598	2.598	3.033	3.033	4.055	4.055
G max.	.551	.275	.275	1.319	1.319	.315	.315
G min.	-.039	-.354	-.354	.571	.295	-.590	-.590
H	.689	1.082	1.082	.984	.984	1.102	1.102
J	.787	1.578	1.578	1.771	1.771	1.968	1.968
K	M60x2.0	M74x1.5	M74x1.5	M85x2.0	M85x2.0	M112x2.0	M112x2.0
L	6-M10x95	6-M12x120	6-M12x120	6-M16	6-M16	6-M20x130	6-M20x130
M	1.279	1.535	1.535	1.693	1.693	1.988	1.988
N	2.834	3.740	3.740	6.748	6.748	4.370	4.370
O	3.201	3.201	4.188	4.188	5.501	5.501	7.751
P	.787	.984	1.181	1.181	1.181	1.181	1.181
Q max.	1.496	1.799	1.799	2.007	2.007	2.649	2.649
Q min.	1.370	1.653	1.653	1.834	1.834	2.441	2.441
R max.	.856	.935	.935	1.329	1.801	1.801	1.801
R min.	.903	.462	.462	.581	.620	.620	.620
S	1.181	1.969	1.733	.984	.708	1.417	1.732
T	1.229	1.378	1.378	1.575	1.575	1.968	1.968
U	.472	.551	.551	.630	.630	.708	.708
V	.078	.078	.078	.078	.078	.078	.078
W	2.559	3.149	3.149	3.701	3.701	4.882	4.882

HOW TO ORDER: State quantity, Model Number of chuck and shipping instructions.