



Atlas Workholding Large Diameter ATL Series Open Center Power Chuck 15" thru 24"

Direct replacement chucks for Kitagawa B Series

- ⊕ Easy retrofit
- ⊕ Interchangeable Top Tooling 1.5mm x 60° serrations 15" and 18" chucks and 3mm x 60° on 21" and 24" chucks
- ⊕ High speed
- ⊕ Full 1 year warranty parts and labor
- ⊕ Hardened jaw ways, master jaws and internal parts
- ⊕ Large thru-holes, plus Quick Change cover plate for closed center applications.
- ⊕ Chuck accuracy plus/minus .0005" repeatability

Model No.	Mount	Thru Hole Dia	Jaw Stroke Dia	Sleeve Stroke	Gripping Capacity		Draw Bar Pull lb/f	Grip Force lb/f	Max RPM	Wt lbs
					Max	Min				
ATL15-A8 (I)	A2-8	4.626"	.417"	.905"	15.00"	1.181"	15,961	40,465	2500	295
ATL15-A11 (D)	A2-11	4.626"	.417"	.905"	15.00"	1.181"	15,961	40,465	2500	280
ATL18-A11 (D)	A2-11	4.626"	.417"	.905"	17.71"	1.181"	15,961	40,465	2000	392
ATL21-A11 (I)	A2-11	5.512"	.417"	.905"	20.86"	3.425"	20,231	43,940	1700	542
ATL21-A15 (D)	A2-15	5.512"	.417"	.905"	20.86"	3.425"	20,231	43,940	1700	542
ATL24-A11 (I)	A2-11	6.496"	.417"	.905"	24.01"	4.331"	20,231	43,940	1400	670
ATL24-A15 (D)	A2-15	6.496"	.417"	.905"	24.01"	4.331"	20,231	43,940	1400	670

(I) Indirect mount (D) Direct mount

Dimensional Data (in inch)

MODEL	ATL15-A8	ATL15-A11	ATL18-A11	ATL21-A11	ATL21-A15	ATL24-A11	ATL24-A15
A	15.00	15.00	17.72	20.86	20.86	24.01	24.01
B	6.299	5.860	5.860	6.338	6.338	6.693	6.693
C	11.811	11.811	14.960	14.960	14.960	14.960	14.960
D	5.501	7.751	7.751	11.251	11.251	11.251	11.251
E	1.299	.866	.866	.866	1.063	.866	1.063
F	.234	.234	.234	.234	.234	.234	.234
G	9.252	9.252	9.250	13.000	13.000	13.000	13.000
H	6.748	9.552	-	9.252	13.000	9.252	13.000
J	4.626	4.626	4.626	5.511	5.511	6.496	6.496
K	6-M20	6-M20	6-M20	6-M22	6-M22	6-M22	6-M22
L	.945	1.102	1.102	1.338	1.338	1.378	1.378
M	1.693	1.693	1.693	2.362	2.362	2.362	2.362
N max	3.228	3.228	3.228	3.878	3.878	4.252	4.252
N min	3.016	3.016	3.016	3.669	3.669	4.043	4.043
O max	1.722	1.722	3.081	3.445	3.445	4.626	4.626
O min	.718	.718	.718	.846	.846	.846	.846
P max	1.732	1.142	1.299	1.496	1.496	1.850	1.850
P min	.827	.236	.394	.590	.590	.945	.945
Q	.244	.244	.244	.256	.256	.256	.256
R	.866	.866	.866	.866	.866	.866	.866
S	1.555	1.555	1.555	1.555	1.555	1.575	1.575
T	.197	.197	.197	.197	.197	.197	.197
U max	M130x2.0	M130x2.0	M130x2.0	M155x2.0	M155x2.0	M175x2.0	M175x2.0
V	6-M16	-	-	6-M20	-	6-M20	-
W	2.362	2.362	2.362	3.146	3.146	3.146	3.146
X	2.756	2.756	2.756	2.874	2.874	2.874	2.874
Y	6.496	6.496	6.496	7.046	7.046	7.046	7.046
Z	5.472	5.472	5.472	6.693	6.693	7.362	7.362

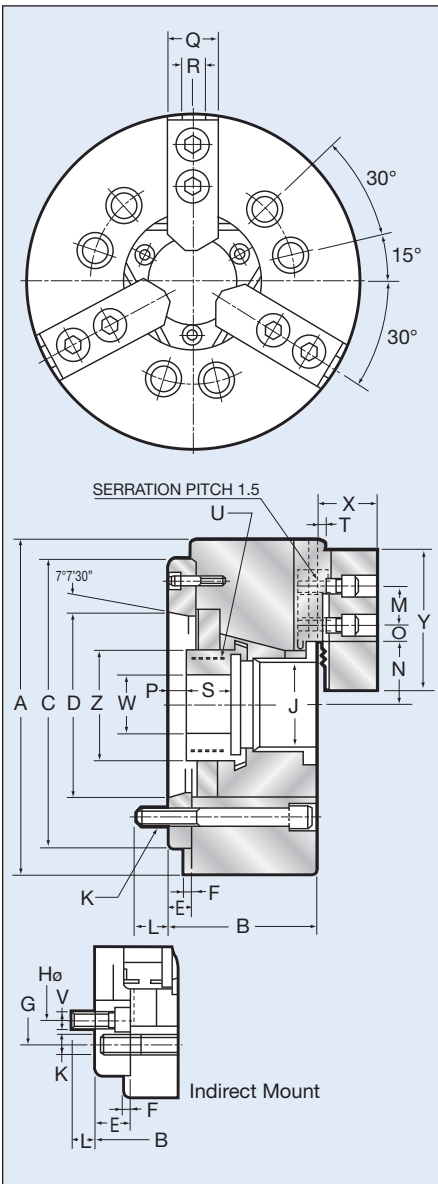

HOW TO ORDER: State quantity, Model Number of chuck and shipping instructions.