

PBA Pratt Burnerd MK3 3-Jaw Self-Centering Power Chucks



Chuck shown with optional hard reversible top jaws.

Power Chucks

Turn your engine lathe into a production machine with this easy retrofit self-contained power chuck.

- ⌚ One-year warranty
- ⌚ Precision manufactured to fit types A and D spindles and adapter mounting
- ⌚ Repetitive gripping within .001" TIR
- ⌚ Safe, Chuck operates independently of air supply when gripping
- ⌚ No separate actuating cylinder
- ⌚ No draw tube to restrict thru-hole
- ⌚ Sizes 6 1/2", 8", 10", 12", and 14"
- ⌚ Suitable for chucking or barwork
- ⌚ Less overhang. Lighter in weight
- ⌚ Minimum maintenance
- ⌚ Quick, simple Lever or Foot Pedal Operation
- ⌚ Easy installation ref. page 39
- ⌚ Optional top jaws ref. page 39
- ⌚ 1/16" x 90° serrated master jaws standard

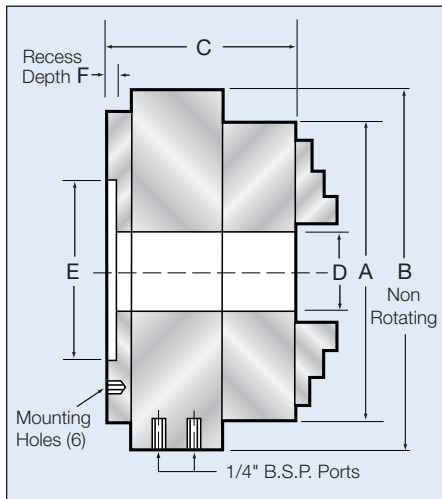

Dimensions are for adapter mount chucks.

Chuck Size	Adapter Mount Model No.	Type D Spindles		Type A Spindles	
		Spindle Size	3-Jaw Model No.	Spindle Size	3-Jaw Model No.
6 1/2"	3-Jaw 9760-01710	D-3	9762-21710	-	-
		D-4	9762-31710	-	-
		D-5	9762-41710	A-5	9761-31710
		D-6	9762-51710	A-6	-
8"	3-Jaw 9760-02110	D-4	9762-32110	-	-
		D-5	9762-42110	A-5	9761-32110
		D-6	9762-52110	A-6	9761-42110
10"	3-Jaw 9760-02610	D-5	9762-42610	-	-
		D-6	9762-52610	A-6	9761-42610
		D-8	9762-62610	A-8	9761-52610
12"	3-Jaw 9760-03210	D-8	9762-63210	A-8	9761-53210
		D-11	9762-73210	A-11	9761-63210
14"	3-Jaw 9760-03510	D-8	9762-63510	A-8	9761-53510
		D-11	9762-73510	A-11	9761-63510

Table Mount, "L" Type Mounts and Special Mounts available upon request.

Dimensional and Technical Data (in inch)

Chuck Size	A	B	C	D	E	F	Mtg Hole	6-Hole B.C.	Wt. Lbs	Max rpm*	Jaw Travel	Ext. Gripping Range Std. Hard Jaws	Int. Gripping Range Std. Hard Jaws	Force**
6 1/2	6.50	9.45	5.06	1.50	4.921	.24	M10	5.91	50	3000	.180	.63 to 7.09	2.80 to 7.80	6,930
8	7.87	10.63	5.16	2.05	6.102	.24	M10	7.09	68	2500	.180	.98 to 8.62	3.58 to 9.58	10,230
10	9.84	12.20	5.73	2.56	7.283	.24	M10	8.27	100	2000	.197	1.22 to 10.71	4.45 to 11.39	15,180
12 1/2	12.40	13.98	5.79	3.54	8.858	.26	M10	9.84	144	1500	.197	1.57 to 13.35	5.31 to 14.69	18,080
14	13.78	15.35	7.28	5.59	10.000	.26	M12	11.00	200	1300	.236	3.50 to 14.60	7.30 to 15.90	18,960

*Max. RPM at 85 PSI with standard hard top jaws. Consult factory for increased RPM rating.

** Total Gripping Force (lbs) at 85 PSI

HOW TO ORDER: State quantity, Model Number of chuck and shipping instructions.

Pratt Burnerd Accessories and Installation For MK3 Self-Contained Power Chucks

Lever Control Unit - Part Number 1157-12800

Foot Pedal Control Unit - Part Number 1157-12801 (Not Shown)



This unit is essential in order to operate MK3 self-contained power chucks. It is designed to be interlocked with the machine spindle so that the chuck cannot be actuated while the spindle is under power. Care must be taken not to actuate the chuck while the spindle is decelerating.

Units are supplied complete with pressure gage, pressure regulator, oil mist lubricator, air filter and lines with fittings.

Unit is operated by air and 110 volt/60 cycle (24 volt DC on request).

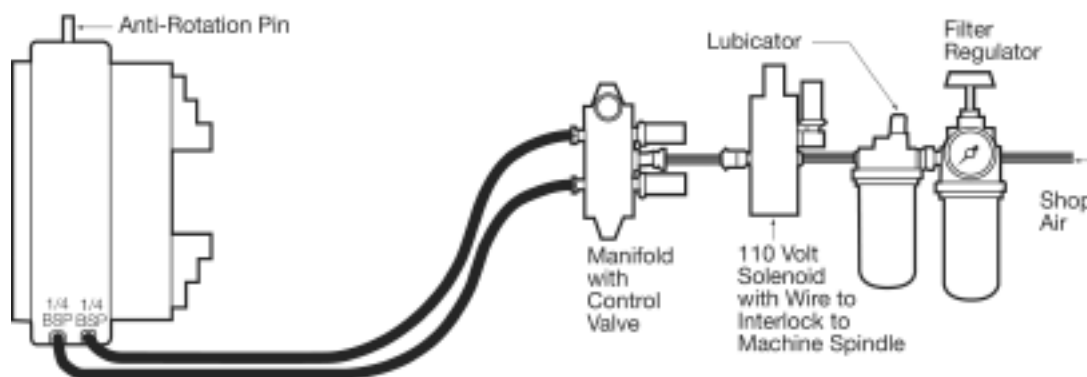

Top Jaws for MK3 Self-Contained Chucks - 1/16" x 90° Serrations

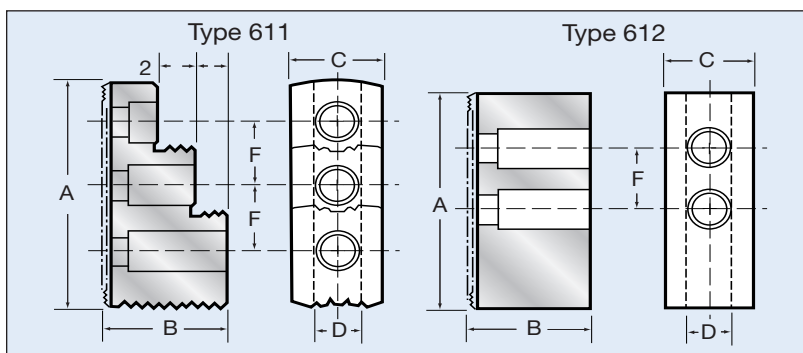

Type 611 - Hardened and ground reversible jaws with serrated gripping faces. (supplied in sets of 3 for 3 jaw chucks only)

Type 612 - Soft blank jaws, case hardening quality steel. (supplied as single units only)

Dimensional Data

Chuck Size	Jaw Type	Part Number	A	B	C	D	F	Bolt Size	Step Height
6½"	611	8130-17611	2.56"	1.56"	1.18"	.475"	.67"	M8	.39"
6½"	612	8140-17512	2.75"	1.50"	1.25"	.475"	.787"	M8	-
8"/10"	611	8130-21611	3.00"	1.97"	1.57"	.670"	.75"	M12	.47"
8"/10"	612	2860-21512	3.50"	2.00"	1.50"	.670"	1.00"	M12	-
12"/14"	611	8130-31611	4.92"	2.36"	2.36"	.830"	.98"	M16	.55"
12"/14"	612	2860-32512	4.50"	2.50"	2.00"	.830"	1.25"	M16	-